

COREtec[®]

the Original



CORETEC PLUS[®]

ANGLE TAP INSTALLATION INSTRUCTIONS



COREtec Plus® Plank & Tile Floating Installation Instructions

ATTENTION!
READ BEFORE INSTALLING!

FOR BEST VISUAL REPRESENTATION OF YOUR FLOOR

This flooring replicates the look of a natural product which has natural variations in color, texture, and sheen/gloss. For best visual effect, shuffle planks or tiles from several cartons and do not install similar planks or tiles next to one another.

Subfloor Preparation

Subfloor should be dry and level to 3/16" per 10 ft. radius for best installation results.

Angle-Tap Installation Instructions for COREtec Brand Floors

READ THESE INSTRUCTIONS THOROUGHLY BEFORE BEGINNING INSTALLATION.

If the following instructions leave any unanswered questions or if additional information is required, please call COREtec toll free at 844-743-7429.

Flooring Material Should Be Inspected Prior to Installation

Responsibility for the suitability of COREtec® flooring and accompanying products for each individual installation cannot be assumed by COREtec, since COREtec has no control over the installer's proper application. Should an individual plank or tile be doubtful as to appearance or dimension the installer should not use this piece. COREtec will send a replacement in a timely fashion.

NOTE: COREtec Plus floors may be installed with a direct glue-down method on approved wooden (or) concrete substrates that are on or above grade only. Use only COREtec Cork Underlayment Adhesive (or) comparable premium multi-purpose adhesives. Please consult with adhesive manufacturer to determine if suitable for use with this material.

Read Before Installing

While COREtec Plus is waterproof, it's not a moisture barrier. It's still a good idea to make sure concrete is cured and tested for moisture and that a moisture barrier is installed in the crawl space and even under a

COREtec Plus floor over a concrete subfloor. Moisture won't damage COREtec Plus, but it can get in the walls and structure of the home. A couple of extra dollars and a few minutes is a small investment for the added protection and peace of mind.

Because houses and buildings, as well as adjacent hardwood or laminate floors, expand and contract, COREtec recommends to leave a ¼" expansion gap between the perimeter walls and any adjacent hardwood floor.

Do not install COREtec Plus floors as a floating floor where it will be exposed to temperatures greater than 140° F. In areas where the floor may be exposed to direct, intense sunlight resulting in excessive heat to the floor, use the glue down method.

Use good common sense installation practices, and you'll have a successful installation that results in a beautiful floor.

Pre-Installation Jobsite Requirements

COREtec cannot be held responsible for site conditions.

Carefully examine the flooring prior to installation for color, finish, sheen, and quality. Ensure adequate lighting for proper inspection. **If flooring is not acceptable, contact your supplier immediately and arrange for a replacement.** COREtec cannot accept responsibility for flooring installed with visible defects. Prior to installation of any flooring, the installer must ensure that the jobsite and subfloor meet the requirements of these instructions. COREtec is not responsible for flooring failure resulting from unsatisfactory jobsite and/or subfloor conditions.

Flooring should be one of the last items installed in any new construction or remodel project.

Crawl spaces must be a minimum of 18" (46 cm) from the ground to the underside of the joists. A ground cover of 6–20 mil black polyethylene film is essential as a vapor barrier. Joints must be lapped 6" (15 cm) and sealed with moisture resistant tape. The crawl space should have perimeter venting equal to a minimum of 1.5% of the crawl space square footage. These vents should be properly located to foster cross ventilation. Where necessary, local regulations prevail.

Room temperature and humidity of installation areas should be consistent with normal, year-round living conditions for at least one week before installation of flooring. Maintaining an optimum room temperature of 70° F and a humidity range of 30-50% is recommended.

To learn more about COREtec, visit www.coretecfloors.com

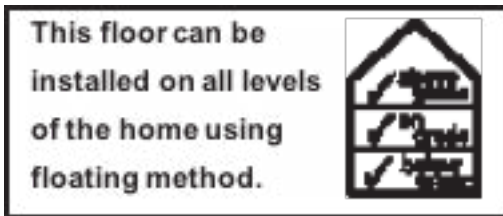

PRE-INSTALLATION SUBFLOOR REQUIREMENTS

All Subfloors must be:

- Dry
- Structurally sound
- Clean: Thoroughly swept and free of all debris
- Level: Flat to 3/16" per 10-foot radius

Wood subfloors must be dry and well secured. Nail or screw every 6" along joists to avoid squeaking. If not level, sand down high spots and fill low spots with a Portland-based leveling patch.

Concrete subfloors must be fully cured, at least 60 days old, and 6-mil polyfilm is recommended between concrete and ground. Subfloor should be flat and level within 3/16" per 10' radius. If necessary grind high spots down and level low spots with a Portland- based leveling compound.

Ceramic tile, resilient tile and sheet vinyl must be well-bonded to subfloor, in good condition, clean, and level. Do not sand existing vinyl floors, as they may contain asbestos.

Installation Tools

For all installation methods:

- Tape measure
- Chalk Line
- 3M Scotch Blue™ 2080 Tape
- Hammer
- Pull Bar
- Pencil
- Crosscut Power Saw
- ¼" Spacers
- Tapping Block

Acceptable Subfloor Types:

- CDX Underlayment Grade Plywood (at least ½" thick)
- Underlayment Grade Particleboard
- OSB (at least ¾" thick)
- Existing Wood or Laminate Floor
- Resilient Tile
- Concrete Slab
- Ceramic Tile
- Non-Cushioned Sheet Vinyl

STARTING YOUR INSTALLATION

Because houses and buildings, as well as adjacent hardwood or laminate floors, expand and contract, COREtec recommends leaving a ¼" expansion gap between the perimeter walls and any adjacent hardwood floor.

Work from several open boxes of flooring and "dry lay" the floor before permanently laying the floor. This will allow you to select varying textures, colors, and sheens, and to arrange them in a harmonious pattern. Remember, it is the installer's responsibility to determine the expectations of what the finished floor will look like with the end user first and then to cull out pieces that do not meet those expectations.

Begin installation next to an outside wall. This is usually the straightest and best reference for establishing a straight working line. Establish this line by measuring an equal distance from the wall at both ends and snapping a chalk line. The distance you measure from the wall should be the width of a plank or tile. You may need to scribe cut the first row of planks or tiles to match the wall in order to make a straight working line if the wall is out of straight.

You may want to position a few rows before starting installation to confirm your layout decision and working line. When laying flooring, stagger end joints from row to row by at least 8" (20 cm) for planks, and equal to 12" (51 cm or a half piece) for tiles. For plank installations, you can use the cut-off end to begin the next row when cutting the last plank in a row to fit. If cut-off end is less than 8", discard it and instead cut a new plank at a random length (at least 8" in length) and use it to start the next row. For tile installations, always begin a row with either a full tile or a half tile so that the joints are consistently staggered in a "brick work" type pattern. Always begin each row from the same side of the room.

Installation Instructions

1 PRE-INSTALLATION GUIDELINES

These installation guidelines apply to the COREtec Angle Tap product. All instructions and recommendations should be followed for a successful installation.

Required Tools: Tape Measure, Utility Knife, Jigsaw, Tapping Block or Rubber Mallet, Pull Bar, ¼" Spacers, T-Square, Safety Glasses, Broom or Vacuum and, if necessary, tools for subfloor repair.

Frequently moved furniture should be equipped with felt pads to avoid scratching the floor. Heavy furniture and appliances should be equipped with non-staining large surface floor protectors. Furniture with casters or wheels must be easy swiveling, large surface non-staining and suitable for resilient floors. Do NOT use ball type casters as they can damage the floor.

- This product can be installed on, above, or below grade.
- COREtec floor covering is an interior product and must be stored/installed in a temperature-controlled interior environment, maintained between 55 and 85 degrees F or 13°-29°C.
- Excessive moisture in the subfloor could promote mold, mildew, and other moisture related issues that will contribute to an unhealthy indoor environment. COREtec is not responsible for damages related to these moisture issues. COREtec recommends a 6 mil polyfilm when installing over concrete subfloors.
- Avoid prolonged exposure to direct sunlight as this will result in discoloration. The use of drapes, blind systems or protective window film is required.
- Flooring should be installed after all other trades have completed work that could damage the flooring.
- All subfloor patching must be completed with a Portland based compound and fully dried/cured prior to installation.
- Inspect all planks for damage prior to installation. If you have any concerns about the product fit or finish, call COREtec Tech Services at 844-743-7429. Claims/ Returns will not be accepted for any flooring that has been cut to size and/or installed.
- Blend and install planks from several cartons.

2 SUBFLOOR PREPARATION

All subfloors must be clean, flat, dry and structurally sound. Proper subfloor preparation is a major part of a successful installation. Subfloor must be flat – 3/16" in 10' or 1/8" in 6'. Moisture emissions should not exceed 5.0 lbs per 1000 sq. ft. for 24 hours and should not exceed a relative humidity of 85%. We also recommend a 6 mil polyfilm moisture barrier to help prevent the growth of mold and mildew. When installing below grade, a 6 mil polyfilm is required.

Over Existing Floors

- Installation is NOT allowed over any type of carpet.
- COREtec flooring can be installed over most existing hard-surface floor coverings, provided that the existing floor surface is clean, flat, dry and structurally sound.
- Existing sheet vinyl floors should not be heavily cushioned. Soft underlayment and soft substrates will diminish the product's inherent strength.
- Never use solvents or citrus adhesive removers to remove old adhesive residue. Solvent residue left in and on the subfloor may affect the new floor covering.

Radiant Heat

Radiant heat systems must have a minimum of 1/2" separation from the product. Maximum operating temperature should never exceed 85°F (30°C). Use of an in-floor temperature sensor is recommended to avoid overheating.

3 INSTALLATION

COREtec is engineered to be installed utilizing the floating method. Do not install cabinets or fixed objects on top of the COREtec. Proper expansion space is required. Undercut all doorjambes. Do not fasten wall moldings and or transition strips to the floor and planks.

See Following Pages for **Step-by-Step Illustrations**

INSTALLATION

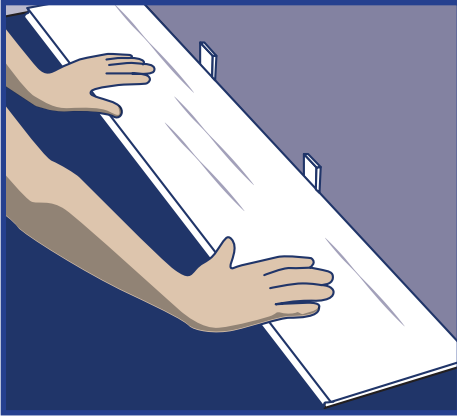

Step 1: Begin installation working from left to right. Insert spacers at ends and edges where planks meet wall.

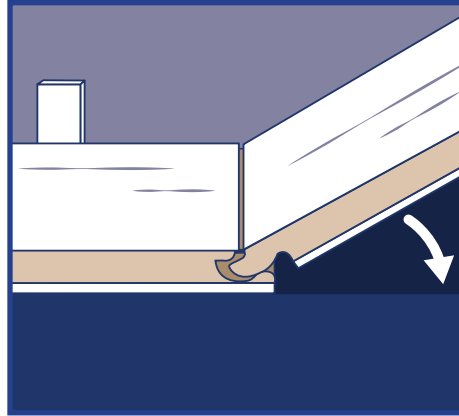

Step 2: Lock short end of plank by inserting tongue into groove at an angle and drop in place. Continue to end of first row.

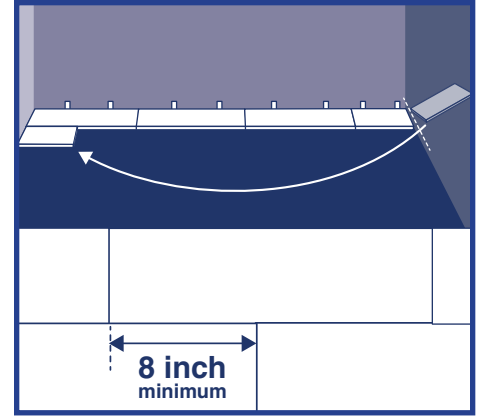

Step 3: Use leftover plank from first row as starter for second row. There must be at least 8" between plank end joints on adjacent rows.*

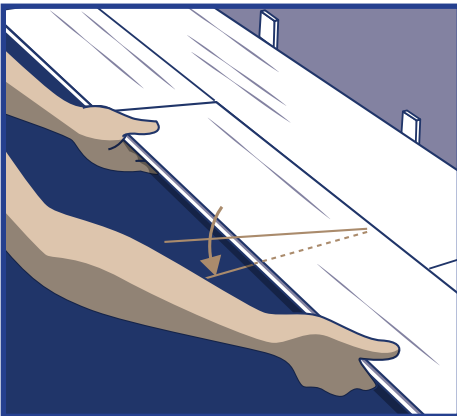

Step 4: Lock long edge of plank by inserting tongue into groove at an angle and drop in place. Slide plank toward end of previously installed plank until the tongue just touches the groove.

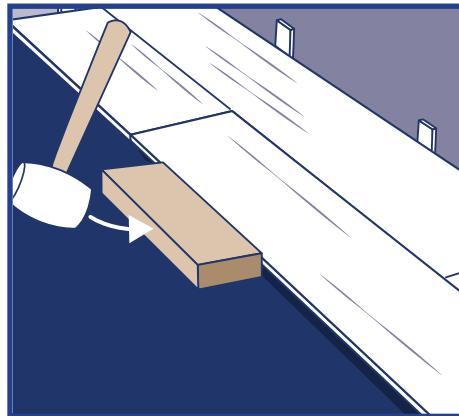

Step 5: IMPORTANT! Use hammer and tapping block to tap long edge of plank to ensure a tight fit. **ANY GAPPING CAN COMPROMISE THE LOCKING SYSTEM!**

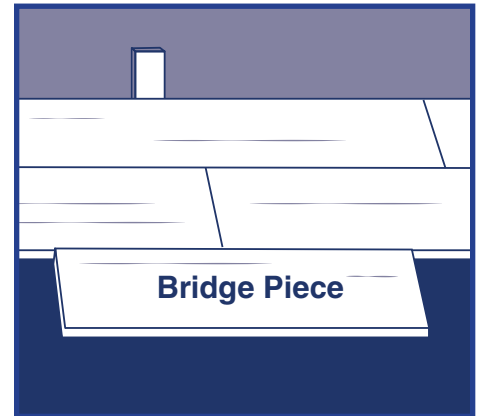

Step 6: Attach a scrap piece of floor to bridge gap between ends of planks.

**FOR TILE INSTALLATIONS: The distance between end joints should be equal to 12" for proper appearance.*

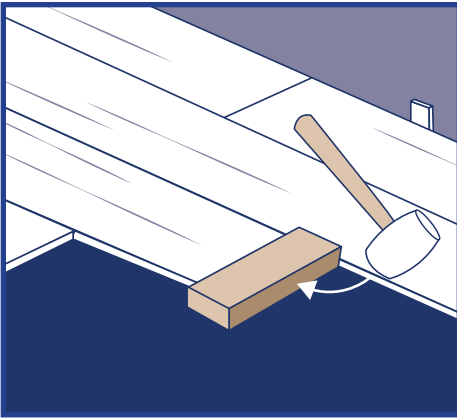

Step 7: Tap end of plank with hammer and tapping block to lock ends of planks together. Remove bridge and continue towards wall until installing the final plank in the row. **BE SURE TO TAP ON EDGE OF VINYL SO AS NOT TO DAMAGE LOCKING PROFILE.**

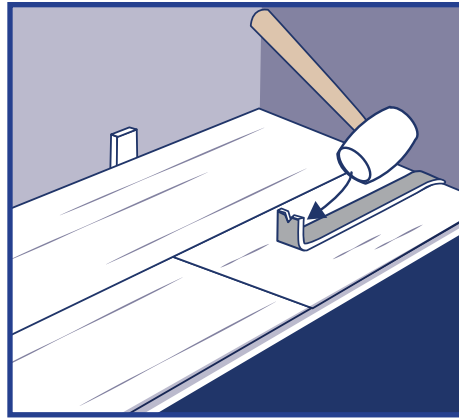

Step 8: Use hammer and pull bar to lock final piece in row. Insert spacer at end of row. Continue installation to final row.

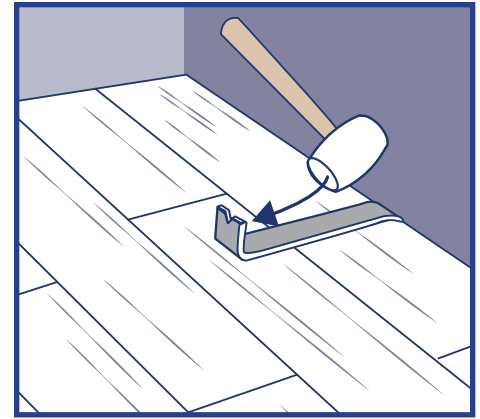

Step 9: Use hammer and pull bar to lock long edges of planks on final row.

INSTALLING UNDER DOOR JAMBS

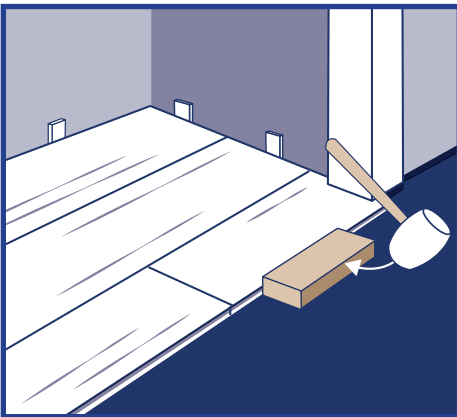

Step 1: Undercut space under door jamb to allow plank to slide freely. Tap long edge with hammer and tapping block to lock long edge.

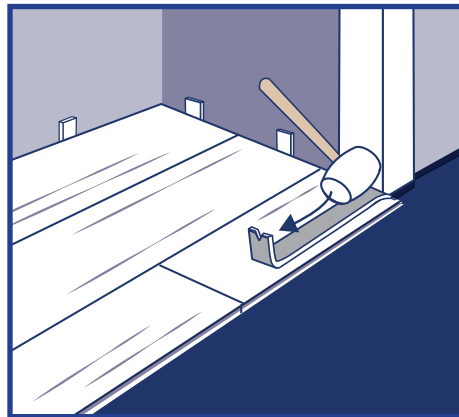

Step 2: Use hammer and pull bar to lock short end of plank.

Installation video: <https://www.youtube.com/watch?v=RGi0YUcPsMA>

In-floor Radiant Heat

COREtec Plus can be installed over 1/2" embedded radiant heat using the floating or glue down method. When gluing floor, use only COREtec cork underlayment adhesive over manufacturer's recommended substrate.

- Turn the heat off for 24 hours before, during and 24 hours after installation when installing over radiant heated subfloors.
- Failure to turn the heat off may result in significantly shortened working time of the adhesive.
- Floor temperature must not exceed 85°F (30°C). Once the installation has been completed, the heating system should be turned on and increased gradually (5 degree increments) until returning to normal operating conditions.
- Failure to strictly follow adhesive manufacturer's guidelines may result in failure and void the warranty.

Warning: Electric heating mats that are not embedded in to the subfloor are not recommended for use underneath COREtec Plus floors. Using electric heating mats that are not embedded and applied directly underneath COREtec Plus floors could void the warranty for your floor in case of failure. It is best to install COREtec Plus flooring over embedded radiant floor heating systems and adhere to the guidelines listed above.

AFTER INSTALLATION

- Flooring should be one of the last items installed in a project. In order to protect the floors while other trades are finishing their work prior to final cleanup and turnover to the owner, use rosin paper and only use 3M Scotch-Blue™ 2080 Tape to hold the rosin paper to the floor (other blue tapes may damage the finish). Clean the floor thoroughly before laying the rosin paper to ensure that no debris is trapped underneath. DO NOT USE plastic film or other non-breathing coverings as this can cause the floor to become damaged from humidity buildups.
- Dust-mop or vacuum your floor to remove any dirt or debris.
- It is suggested that you clean the floor using a recommended pH neutral cleaner available at www.1877floorguy.com/usflcoplevp.html.
- Install any transition pieces that may be needed (reducers, T-moldings, etc.).

Protection and Maintenance of Your Floor

Lasting beauty can be achieved through purchasing a quality floor covering and providing proper on-going maintenance.

- Furniture should be moved onto the newly installed floor using an appliance hand truck over hardboard runways.
- Avoid prolonged exposure to direct sunlight as this will result in discoloration and expansion. The use of drapes, blind systems or protective window film is required.
- Do not expose COREtec Plus floors to temperatures exceeding 140° F.
- Oil or petroleum-based products can result in surface staining. Do not track asphalt driveway sealer or automobile oil drips onto the vinyl floor covering.
- Caster wheeled chairs should have wide, rubber casters. Protective mats are required under office chairs.
- Use non-staining mats. Rubber may discolor the floor.
- Frequently moved furniture should be equipped with felt pads to avoid scratching the floor. Heavy furniture and appliances should be equipped with non-staining large surface floor protectors. Furniture with casters or wheels must be easy swiveling, large surface non-staining and suitable for resilient floors. Do NOT use ball type casters as they can damage the floor.
- Use walk off mats at entrances to prevent dirt and grit from being tracked on to the floor.
- Sweep or vacuum the floor regularly to remove loose dirt. Do NOT use vacuums that use a beater bar or turn beater bar off.
- Do NOT use electric brooms with hard plastic bottoms with no padding.
- Clean up spills immediately.
- Damp mop as needed using clean water and a diluted pH Neutral cleaner (Bona Stone Tile and Laminate Cleaner, Hilway Direct HD pH Neutral Cleaner, etc.). Do NOT use harsh cleaners or chemicals on the floor. Do NOT use abrasive scrubbing tools. Do NOT use detergents, abrasive cleaners or "mop and shine" products.
- Vinyl flooring, like other types of smooth floors, may become slippery when wet. Allow time for floor to dry after cleaning. Immediately wipe up wet areas from spills, foreign substances or wet feet.