

BD_SW_KIT_40 HONDA CBR1000 RR , HRC 2020 onwards race switch set + Interface
For clutch post or handlebar clamp mounting.
Left and right switch set

This left and right switch assembly designed specifically for use on the CBR1000 RR equipped with the HRC kit. Comprising a 7 function left switch, 6 function right switch and an interface module.



Left side - Direct mount onto the handlebar via our generic 22mm clamp or onto the clutch post to save handlebar space, this provides extra clearance for thumb brakes and brake adjusters. Choose your preference when ordering – page 3

Right side – Direct mounting onto one of our brake clamps. See options on page 4

Wiring - No modification of the bike wiring is necessary; this kit plugs directly into the connectors of the HRC loom**



**Rain light switch is provided but requires wiring in, refer to HRC manual for the power supply.

This switch set has been designed to operate together, so are sold as a KIT rather than individually.

Kit comprises:

- Left switch BD-SW-7BC-40 + Mount clamp of your choice
- Right switch BD-SW-6BC-40 + Mount clamp of your choice
- Control module to interface with the bike electronics

Note: See page 3 for choice of clamps

NOTE : The standard right switch comprises the switch set and twist grip sensor. Fitting this kit will require the purchase of the HRC separate throttle grip sensor / quick action throttle

FUNCTIONS: The functions of the standard left switch are re-used with the HRC kit for new functions, these are shown below and their new location within our race switch.

Text in brackets is the new HRC function.

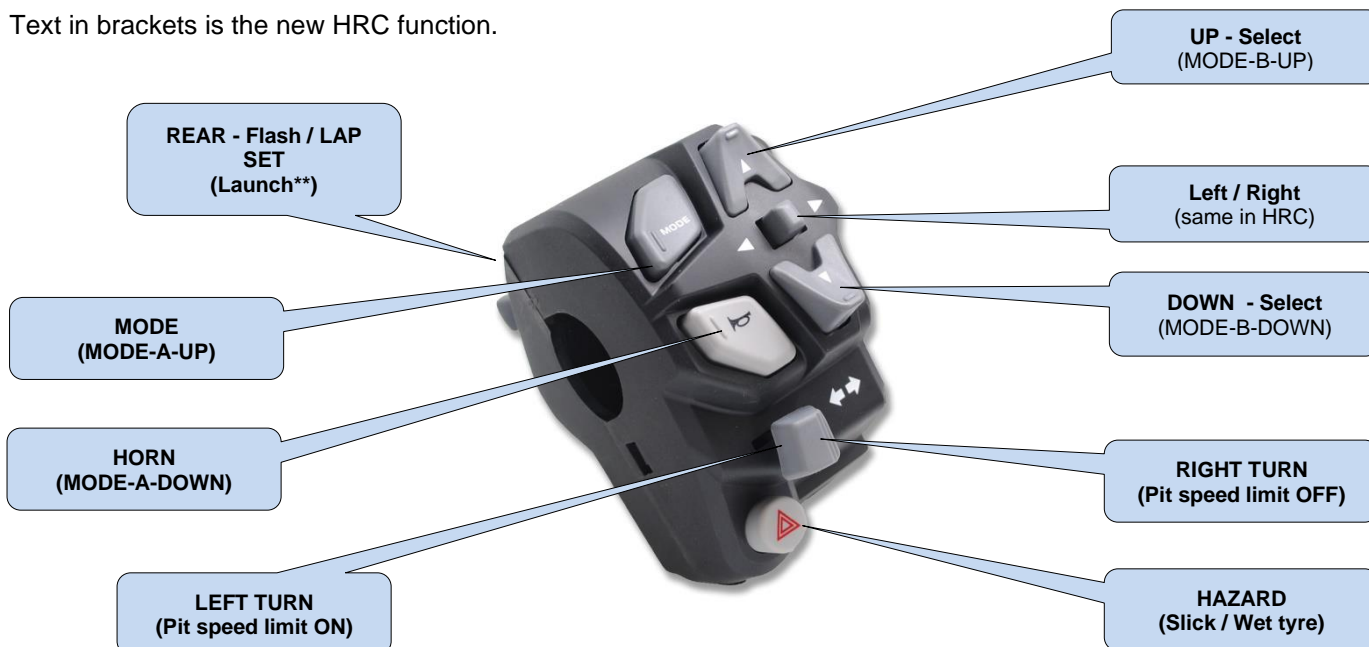

Left side switch – BD-SW-7BC-40

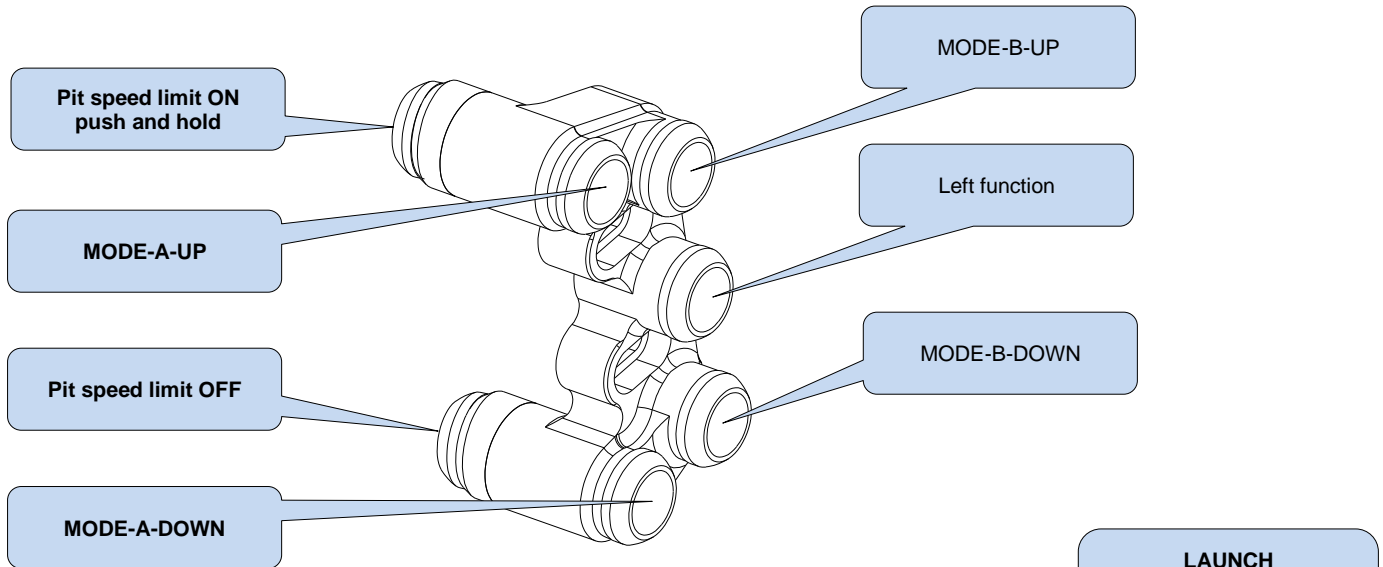

Right side switch – BD-SW-6BC-40

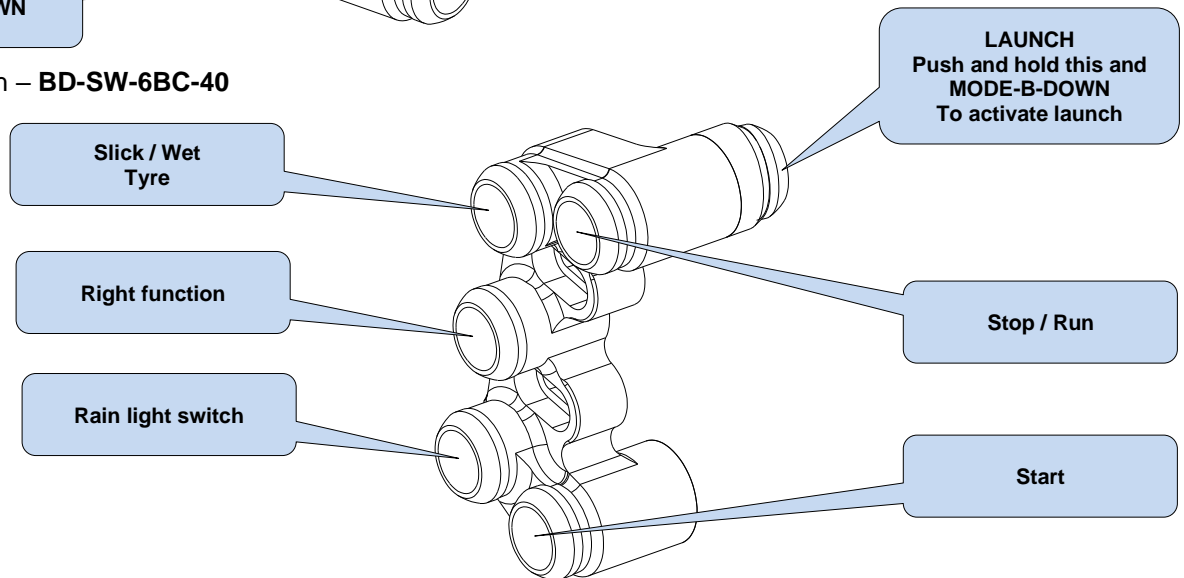

Electrical connection:

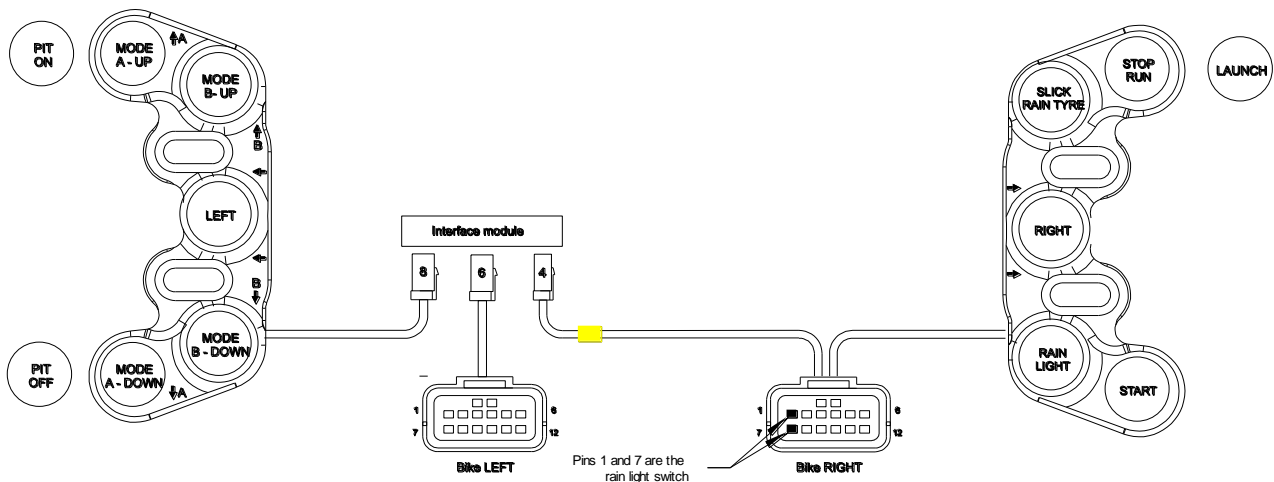

Ordering Information

Part No.	Description
BD-SW-KIT-40-xxx	Honda CBR1000 RR left and right switch set for HRC – 2020 onward xxx - Choose appropriate clamp from the parts listed on page 3 and 4. One free clamp per switch assembly

Left side clutch clamps

Mounting - These 'Type C' switches mount directly onto the handlebar using our generic '2 piece' clamp. Or you can choose from any of the bolt mount clamps shown below to match aftermarket clutch posts.

Clamps

CL-A – To suit 32mm in-line clamp bolts – To suit the standard clutch and Brembo RC

CL-B – To suit 30mm offset bolts – Brembo XR , XA , GP

CL-F – To suit 30mm in-line bolts as found on Accosato / Hel

CL-J – To suit 32mm offset bolts as found on Beringer

CL-K – To suit 36mm in-line bolts as found on Kawasaki

BR-G - Generic clamp for direct handlebar mounting.

We will supply clamp **BR-G** to suit the standard bike

These clamp designs use far less space on the handlebar than conventional switch bodies and are fully adjustable.

Mounting - These switches mount directly onto our own clutch post clamp and are adjustable left / right to suit the rider



0.5mm of gap – Used for tightening the clamp.
 $21.5 > 22.2\text{mm}$ dia bar

IMPORTANT CL-A, CL-B, CL-K

Tighten the UPPER bolt first to achieve metal to metal contact, then use the lower bolt to clamp onto the handlebar

Clamps are also sold separately so there is no need to replace the switch if you change your clutch post.

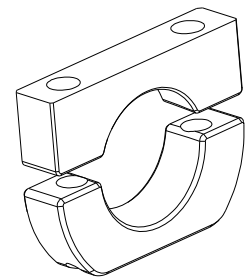
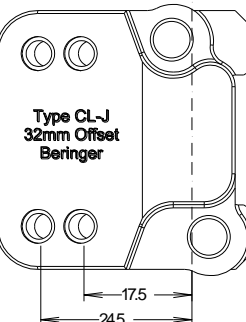
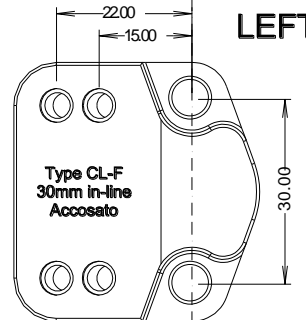
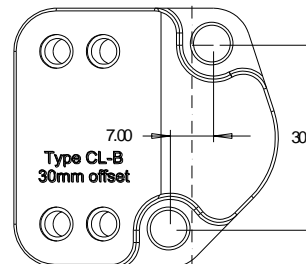
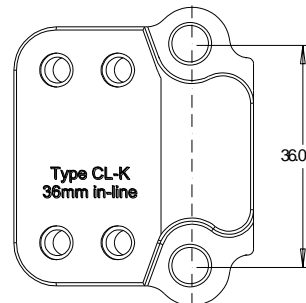
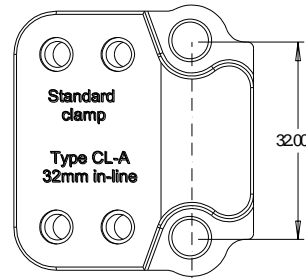

Type G
 Generic clamp
 left or right

LEFT ←

Right side brake clamps

Mounting

These 'Type C' switches mount directly onto our own brake pump clamp(s) and are adjustable left / right to suit the rider

Several clamps are available to suit most popular brakes

BR-A – 32mm in-line bolts

BR-B – 30mm offset bolts to suit Brembo XR / GP brake pump

BR-N – 32mm in-line bolts with left shift, for Nissin / Brembo RC RCS Costa Corta

BR-F – 30mm in-line bolts to suit Accosato / Hel brake pump

BR-J – 32mm offset bolts to suit Beringer brake pump

Specify your clamp at the time of ordering. Clamps are sold separately so there is no need to replace the switch if you change your brake pump.

We will supply clamp BR-A to suit the standard brake, or you can choose from any one of the above as a free alternative.

IMPORTANT

Tighten the UPPER bolt first to achieve metal to metal contact, then use the lower bolt to clamp onto the handlebar – Except BR-F and BR-J which have equal gap for upper and lower



1.0mm of gap – Used for tightening the clamp.
 21.5 > 22.2mm dia bar

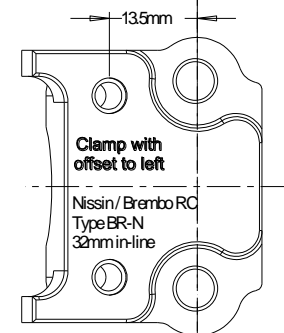
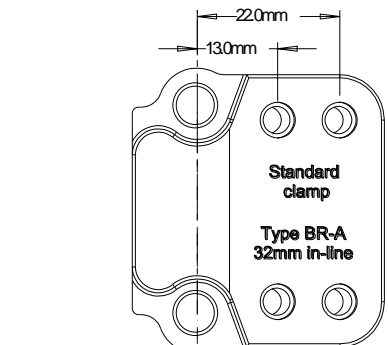

➔ RIGHT

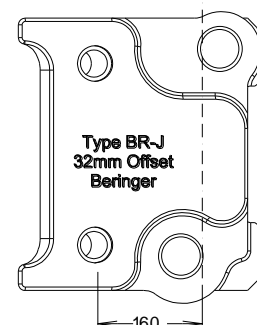
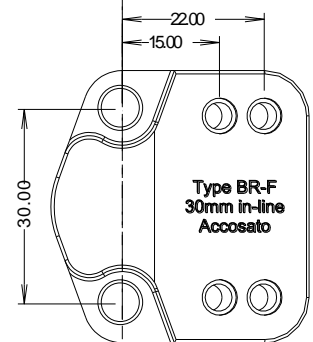
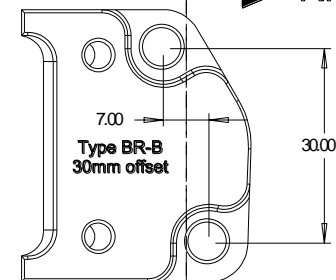

Clamps are also sold separately so there is no need to replace the switch if you change your brake.