

BD-SW-6BC-92 Yamaha MT09 – 2024 onward, 6 button multi-function Handlebar race switch for ‘bar mount’ or direct clutch post mounting

This switch is designed for use on race/track bikes which no longer need the ‘road bike’ functions.

The aluminium assembly has been ergonomically designed for easy use and encompasses 6 momentary switches as described below with direct mounting onto the clutch post or direct to the bar to save handlebar space.

This unique design provides various mounting options giving the installer greater flexibility with other aftermarket products.

Plug ‘n’ Play electrical connection via our dedicated interface module



Function:

Green	Left
Black	Up
Yellow	Select
Black	Down
Green	Right
Black / Rear	Home

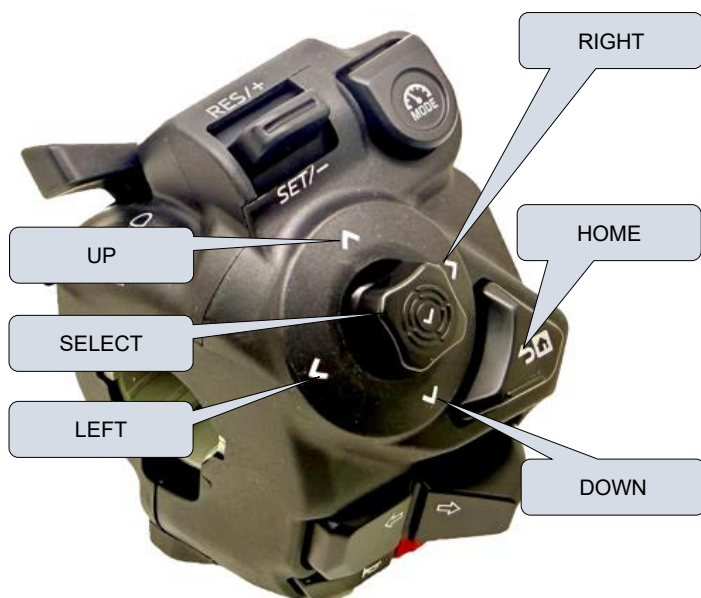
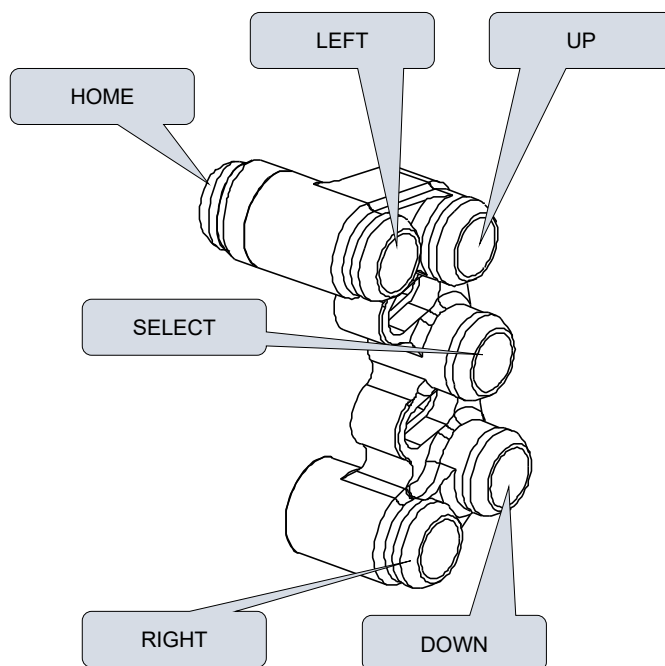

Ordering Information

Part No.	Connector	Description
BD-SW-6BC-92-xxx	Plug n Play	6 way handlebar switch to suit the MT09 from 2024, plus clamp of your choice **See page 3 for clamp options

Electrical connection

These race switches are routed through our own signal conditioning module which also acts as the 'plug n play' connector for the standard wiring loom.

The interface module should be cable tied to the standard wiring loom as far inboard as the wiring permits. This is approximately 200mm away from the new switch assembly.

Ensure you have full and free steering movement after installation.

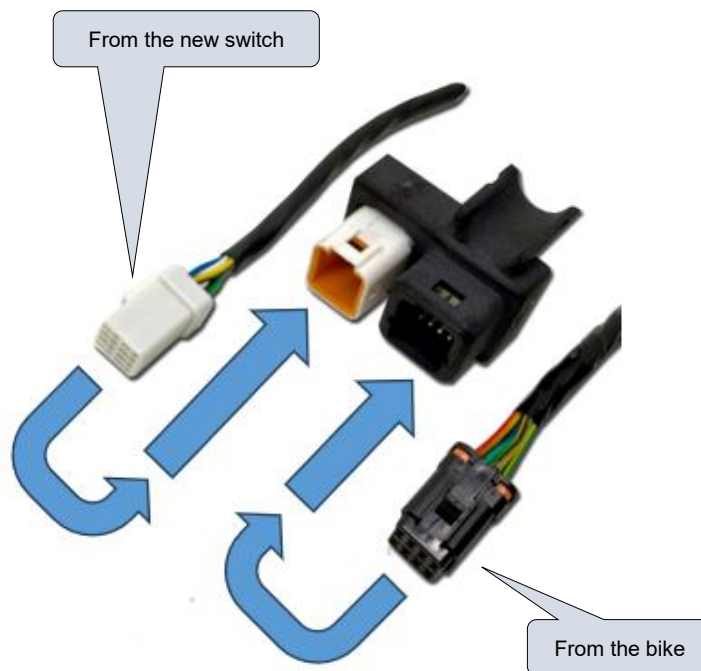

Matching right side products

BD-SW-3BC-92 This 3 way right switch provides the Stop/run, Start, Mode

This also clamps to the standard brake pump to save space on the bars with a choice of clamps to suit whatever brake pump you have fitted.



KT170 – Billet aluminium throttle housing to enclose the standard sensor element within a more compact and stronger casing. This ensures 100% OEM reliability as well as 'plug n play' operation.



Left side clutch clamps

Mounting - These 'Type C' switches mount directly onto the handlebar using our generic '2 piece' clamp BR-G. Or you can choose from any of the bolt mount clamps shown below to match the standard or aftermarket clutch posts.

Clamps

CL-A – To suit 32mm in-line clamp bolts – To suit aftermarket clutch posts

CL-K – To suit 36mm in-line bolts as found on Kawasaki

CL-B – To suit 30mm offset bolts – Brembo XR , XA , GP

CL-F – To suit 30mm in-line bolts as found on Accosato / Hel

CL-J – To suit 32mm offset bolts as found on Beringer

BR-G - Generic clamp for direct handlebar mounting.

We will supply clamp **BR-G** unless otherwise specified when placing the order. Note that **CL-A** matches the standard clutch perch bolt spacing.

These clamp designs use far less space on the handlebar than conventional switch bodies and are fully adjustable.

Mounting - These switches mount directly onto our own clutch post clamp and are adjustable left / right to suit the rider



0.5mm of gap – Used for tightening the clamp.
 $21.5 > 22.2\text{mm}$ dia bar

IMPORTANT CL-A, CL-B, CL-K
 Tighten the UPPER bolt first to achieve metal to metal contact, then use the lower bolt to clamp onto the handlebar

Clamps are also sold separately so there is no need to replace the switch if you change your clutch post.

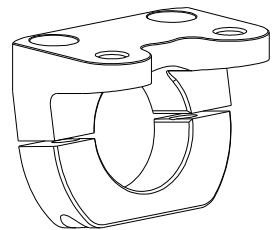
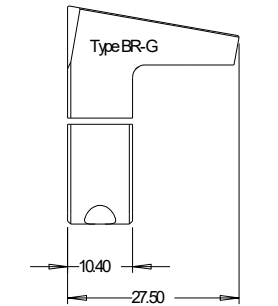
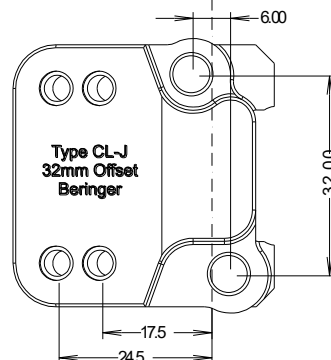
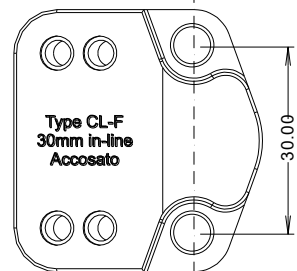
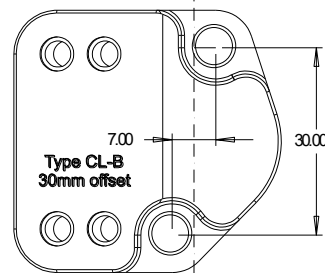
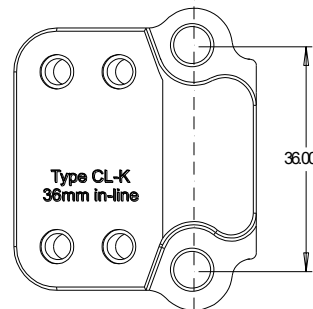
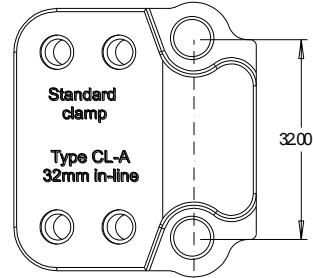

Type G
 Generic clamp
 Left or Right
 Can be used with any of our switch designs

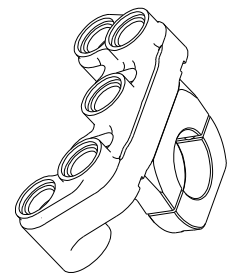

LEFT ←